

# Sofar Spotter™

USER GUIDE

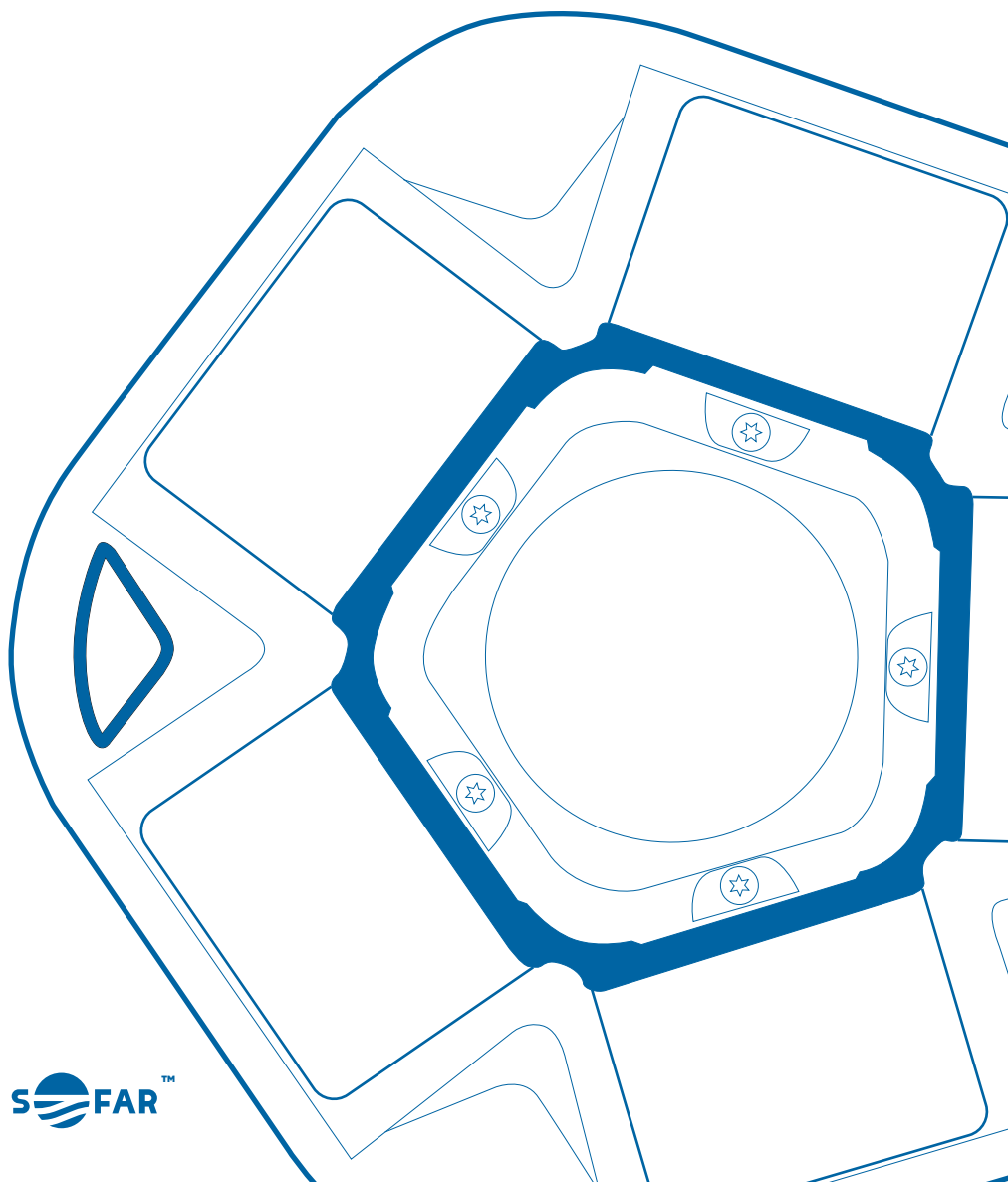

## What is included in this box?

Spotter device.

Spotter Toolkit, which includes:

- 5mm hex key to open and close the lid of the Spotter
- 4mm hex key to disconnect electronics box from hull
- lanyard and magnet to switch from idle to run-mode
- USB cable to upload latest firmware
- power charger to charge the battery prior to deployment
- SD card for data storage during deployment (shipped with unit)
- desiccant with tape to attach to inside of hull before deployment

External ballast chain with bow shackle attached.

Spotter User Guide (this document).

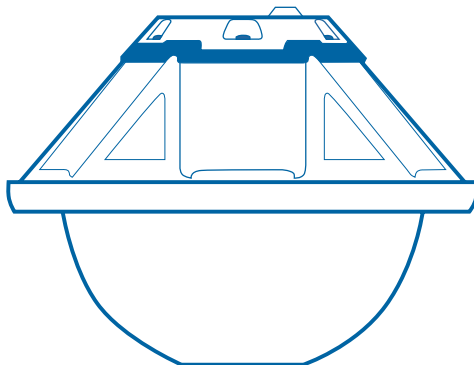



# Sofar Spotter

Spotter is an integrated solution for collecting ocean wave data. The Spotter platform consists of a globally-connected Spotter Device (“Spotter”) and the online Spotter Dashboard.

The Dashboard provides access to real-time Spotter wave and tracking data, system status and alerts, data visualization, and allows you to configure your Spotter remotely.

## Core System Features

<b>2-Way Communication</b>	Remotely change settings on Spotter through online Dashboard
<b>Alerts + Notifications</b>	Set watch perimeter and receive alerts when Spotter moves outside
<b>Spotter API</b>	Access Spotter via our API for seamless application integration
<b>Track Mode</b>	Fast positional updates for tracking Spotter through the Dashboard.



## The core Spotter features

The Spotter device is a compact and lightweight instrument consisting of a waterproof hull, solar panel array, and electronics package.

The Spotter is completely solar-powered so you don't have to replace or recharge the battery during deployment. The solar-battery power system is designed to support Spotter even through higher latitudes and limited light conditions.

Surface to hold magnet to activate magnetic mode switch without removing the lid.

Visibility light. Flashes amber for nighttime visibility.

Captive lid screws (5mm hex) so they do not get lost when lid is removed.

Removable, transparent lid for access to product interface.



Marine-grade materials.

Integrated bottom attachment point for external ballast.

# Spotter User Interface

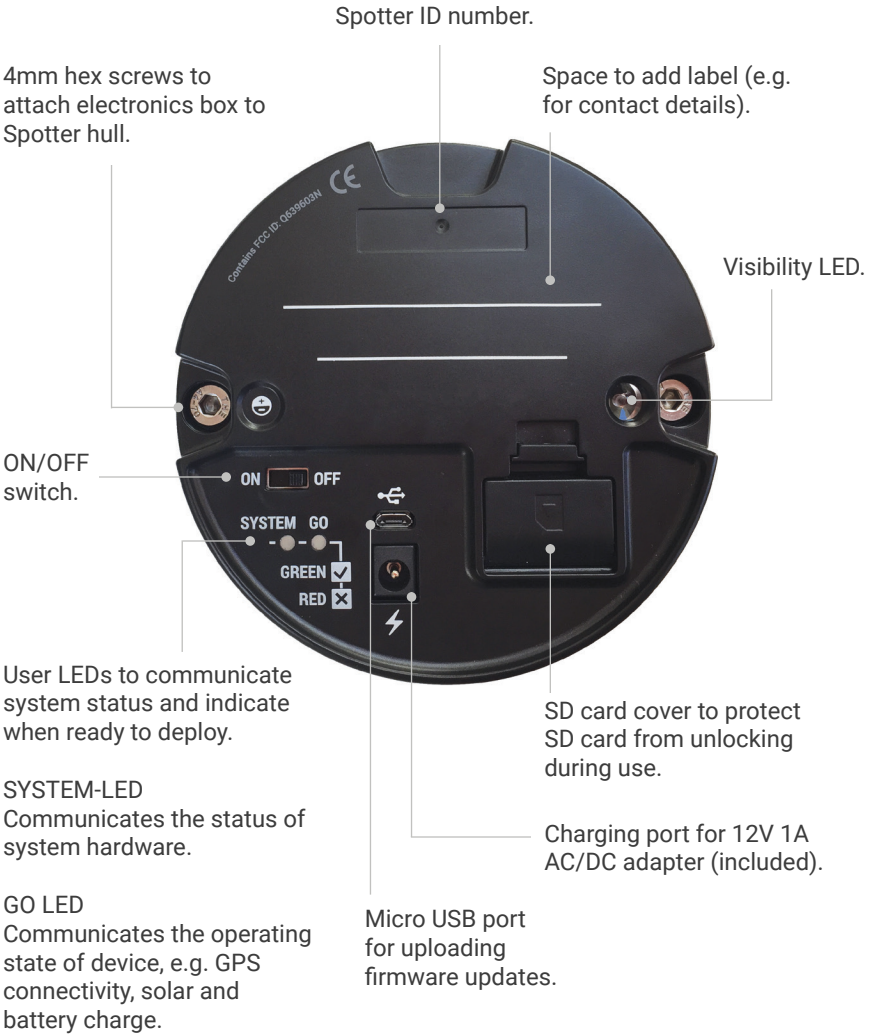

Spotter ID number.

4mm hex screws to attach electronics box to Spotter hull.

Space to add label (e.g. for contact details).

Visibility LED.

ON/OFF switch.

User LEDs to communicate system status and indicate when ready to deploy.

**SYSTEM-LED**  
Communicates the status of system hardware.

**GO LED**  
Communicates the operating state of device, e.g. GPS connectivity, solar and battery charge.

SD card cover to protect SD card from unlocking during use.

Charging port for 12V 1A AC/DC adapter (included).

Micro USB port for uploading firmware updates.

# Getting Started

- 1** Set up your account and Spotter. p. 7
- 2** Set up Spotter device. p. 8
- 3** Deploy Spotter in the water. p. 12
- 4** Check your Spotter Dashboard. p. 13
- 5** Retrieve and Store Spotter. p. 14

# 1

## Set up your account and Spotter

### Set up user account.

Visit <https://spotter.sofaroccean.com/> to set up your user account. Enter personal details and click 'register'. This will take you to the overview page.

### Register your Spotter.

To register your Spotter, click 'register a new device'.

Enter the Spotter ID number and your Activation code, which you should have received by email from the Sofar team. If you have not received this, or do not have this available anymore, please contact Sofar at [support@sofarocean.com](mailto:support@sofarocean.com)

The Spotter ID number is also listed on the device and starts with SPOT-####. Click 'register'.

You will now see your Spotter listed on the overview page. The map will be updated as soon as the first data message is received, which typically takes 1-1.5 hrs from device power on. Please note that message and data transmission require a clear view of the sky with minimal obstruction.



## 2

### Set up Spotter device

The spotter device is completely self-powered and can be operated right out of the box.

#### Check the SD card.

Make sure the system is turned off (on/off switch off) and then check to ensure that the SD card is properly seated.

#### Turn Spotter on.

Switch the on/off switch to the 'on' position to turn Spotter on. During boot-up the two user LEDs will be orange and after startup switch to green. The Spotter device has two possible operating modes - RUN and IDLE-mode - and you can switch between modes using the provided magnet by holding it at the designated area for 3 seconds. The Spotter device will always boot into the last mode it was in before it was switched off.

#### IDLE mode

In IDLE mode, the two LEDs alternate flashing green and the visibility light will be OFF.

IDLE mode is to save power and suspend data acquisition and transmission. That way you can switch to RUN mode without having to open the lid.

Use this mode for short-term inactivity, in preparation for deployment (e.g. transport to deployment site).

#### RUN mode

In RUN mode, the two LEDs are solid green and the amber visibility light flashes periodically.

RUN mode is for full system functionality including: data acquisition, processing, data transmission and on board logging to SD card.

Use this mode during deployment.

Note: Spotter DOES NOT collect data when in idle mode.

### IMPORTANT:

- Spotter needs to be switched into RUN-mode for deployment.
- If Spotter is in IDLE mode, you can switch to RUN mode by holding a magnet onto the recessed area directly on top of the electronics box until the lights turn off. Or in case the transparent lid is screwed on, by holding the magnet onto the recessed round area in the lid for 3 seconds.
- The flashing pattern of the 2 user LEDs and the visibility light will reveal which mode Spotter is in.

When switched to RUN mode, the two user LEDs (SYSTEM and GO) communicate system status and signal when the Spotter is ready to deploy.

### SYSTEM LED

Communicates the status of system hardware.

### GO LED

Communicates the operating state of device, e.g. GPS connectivity, solar and battery charge.

## IDLE mode

---

**SYSTEM**   **GO**   At startup:



**Both solid orange.** System is booting up and running self-check.

After startup:



**Blinking green.** The system is in idle mode. Flashes in alternating pattern between LEDs for 3 minutes and then turns off.

## CHARGING mode

---

In case DC charger is connected and the spotter is turned off, the following charging light sequence can be monitored to track the charging status of the device. Please note that charging the spotter can take as long as 8 hours.















**Both solid green.** System is fully charged.



**Blinking green.** System is charging. Blinks in sync with GO-LED.

## RUN mode

---

SYSTEM	GO	
		<b>At startup:</b>  <b>Both solid orange.</b> System is booting up and running self-check.
		<b>After startup:</b>
		<b>Both solid green.</b> All systems are checked and OK. Ready to deploy. Both LEDs will time out after 60 minutes to save power.
		<b>Blinking green GO LED.</b> System is not solar charging. If this is a night deployment (or the panels are covered), then this is normal and you can deploy. If this is a day deployment, something is wrong with the charging system and you should not deploy.
		<b>Solid red SYSTEM LED.</b> Check if SD card is present. If not, turn off system, place SD card, and switch back on. If the red light persists, there may be a serious system error. Do not deploy until this is resolved. In case that the system LED is solid RED, and this cannot be resolved by inserting a freshly formatted and emptied SD card, please contact the Sofar team.
		<b>Solid red GO LED.</b> Limited GPS connectivity. System may be indoors or no clear view of the sky. If outside, please wait a few minutes while the system establishes a connection with the GPS satellite. If the system has a clear view of the sky and the GO LED remains red for longer than 30 minutes, something may be wrong. In this case, please contact the Sofar team.
		<b>Both solid red.</b> Do not deploy. Follow instructions for red SYSTEM or GO Led as mentioned above.

## 3

### Deploy Spotter in the water

#### Activate Spotter in RUN mode

Switch ON spotter and ensure device is in RUN mode. Ensure both system and status LEDs are green after ~10 minutes with clear view of the sky.

Please note that user LEDs timeout after 60 minutes to save power. After 60 minutes you can see that the system is in RUN mode from the flashing of the visibility LED.

#### Carefully secure lid.

Secure the lid using a 5 mm hex key and hand-tighten the 5 captive screws using a star pattern. The captive screws will bottom out to avoid overtightening them.

#### Attach external ballast

Spotter comes with an external ballast chain that should be attached to the ballast attachment point at the bottom of the hull. For proper data collection and operation, the ballast chain must always be attached prior to deployment.

#### For moored applications: attach mooring to ballast chain.

In case of a moored application, attach the mooring to the end of the external ballast chain.

Note on mooring design:

Sofar Spotter can be deployed either as a free-floating drifter or in a moored configuration. For free floating deployments, the Spotter device comes with everything that is required for deployments.

For moored applications, you will need to design a mooring to anchor the Spotter to the seafloor. Sofar provides some general guidelines based on our experiences. Sofar does not sell moorings, but since we do build moorings for our own Spotters, we share what we have learned from our own testing and from other users. Visit [www.sofaroccean.com](http://www.sofaroccean.com) to download our mooring guidelines.

## Check your Spotter Dashboard

### Login to your account.

Visit <https://spotter.sofaroccean.com/> to login to your user account. Once you are logged in you are on the overview page. If your Spotter has been deployed, it will show as a pulsing dot on the map. In that case, Spotter is set up properly and you can access your data.

Currently the dashboard allows you to:

- view realtime surface wave data from your Spotter,
- search and download historical data for a custom data range,
- track your Spotter on the map so you can plot and estimate surface currents or anticipate a retrieval strategy,
- set a geofence so you get notified when the Spotter detaches from its mooring or otherwise moves outside the set boundaries,
- remotely switch the Spotter into either WAVES or TRACK mode. See 'Spotter Measurements'-section in this User Guide to determine which mode you need for your application.
- access our API so you can integrate ocean data into your own applications,
- review health status of your Spotter (battery, system status) and get notified when something is off,
- change your personal profile.

Besides the features as described above, we are constantly developing new functionality for Spotter, so keep an eye on the Spotter dashboard for the latest news and updates.

Note: Instructions for the dashboard were included in the email that you received with your activation code. So please see the Spotter Dashboard Guide for how to access the features as described above.

## Retrieve and Store Spotter

### **Retrieve the Spotter.**

After retrieval, disconnect the mooring or external ballast weight and rinse off Spotter and mooring/ballast weight with fresh water before storage. If any fouling has built up on the Spotter, this can generally be removed with a soft brush and soapy water.

### **Turn the device off for storage.**

After rinsing, dry the area around the lid, and unscrew the lid using a 5mm hex key. Remove the lid carefully to prevent water from dropping onto the electronics box. After the lid is removed, turn the device off using the on/off switch. At this point you can also remove the SD card and download the data stored on the card to your personal computer.

If you plan to store Spotter for a longer period of time, please see the 'Notes on lithium battery use and storage' below. If you plan to deploy after a prolonged storage, we recommend that you use the included wall charger to fully charge the Spotter before deployment. This ensures that the system can startup and operate without delay.

Notes on lithium-ion battery use and storage.

Spotter units are equipped with a lithium-ion battery pack, which is located inside the electronics box. It is important to handle the Spotter device with care to prevent any possible damage to the electronics and battery pack. For prolonged storage (longer than a week), the Spotter device should ideally be stored in a cool ( $< 25^{\circ}\text{C}$ ) and dry area with the battery at a medium charge,

Lithium-Ion battery packs stored at or near full charge for extended periods of time can experience a reduction in battery capacity. Therefore, if planning to store for longer than 1 week we advise that the battery is not fully charged. One way to ensure proper state of battery charge is to run the system for two days without solar power (in a box or dark room) before turning it off and putting it in storage.



## Spotter Measurements

Currently Spotter has two different run modes enabled: Waves mode and Track mode. These two run modes can be accessed remotely through the online Dashboard. Waves mode is the default and will likely be the mode that is used most of the time. In Track mode, the system will provide faster position updates (e.g. for retrieval), but no wave data.

### Waves mode

---

In Waves mode, Spotter collects wave displacement data continuously at 2.5Hz. Every half hour, the system computes the complete cross-spectral matrix and estimates bulk statistics and Spotter geographical location. To save transmission bandwidth, two time-stamped 30-minute updates of bulk statistics are transmitted every hour. So although the data resolution is 30 minutes, the satellite updates are hourly.

The Standard Waves message payload consists of:

- Time (epoch),
- Position (latitude and longitude),
- Significant Wave Height - estimated from zeroth-order moment of wave spectrum ( $H_{m0}$ ),
- Peak Period - period associated with the peak of the wave spectrum ( $T_p$ ),
- Peak Direction - mean direction at peak of spectrum,
- Peak Directional Spread - directional spreading at peak of spectrum,
- Mean Period - variance-weighted mean period ( $T_{m01}$ ),
- Mean Direction - variance-weighted mean direction,
- Mean Directional spread - variance-weighted mean directional spread.

\*\* All bulk statistics are computed over frequency range 0.03 – 0.8Hz.  
For definitions of various bulk wave statistics see e.g. Holthuijsen (2007).

## Track mode

---

Track mode is designed for faster positional updates of the Spotter device and intended for retrieval of Spotter when in free-drifting mode (or otherwise for tracking). In Track mode messages are transmitted every 15 minutes and the payload contains only positional updates (Spotter does not transmit Wave data when in Track mode). These positional updates can be visualized on the integrated map interface on the Dashboard.

The main purpose of this mode is to track a Spotter and get rapid positional updates for retrieval, which also implies that your data usage rate will be about 4x higher while Spotter is in Track mode.

Although wave data is not transmitted during Track mode, full data is stored to the SD card.

### **Iridium package**

For detail on data subscription and usage rates see:  
<http://bit.ly/2UzXZuw>

# Product Specification

## Data and Connectivity

<b>Connectivity</b>	Iridium SBD (satellite)
<b>Data Storage</b>	<ol style="list-style-type: none"><li>1. Full-size 16GB SD card (on-board) - saves displacement time series, spectra and statistics, surface currents, and positions for one year</li><li>2. Online Dashboard - unlimited real-time wave statistics and tracking data</li></ol>
<b>Applications</b>	Free-drifting: Spotter measures waves, position and surface currents, designed to operate in any current speed. Moored: Spotter measures waves and position.

## Onboard Data Analysis

<b>Spectral output</b>	Function of frequency: variance density spectrum, directional moments, mean direction, directional spreading.
<b>Frequency range.</b>	0.033-1 Hz (30s to 1s)
<b>Frequency resolution</b>	0.0098 Hz (default)
<b>Bulk statistics</b>	significant wave height, mean period, peak period, mean direction, mean directional spread, peak direction, peak directional spread

## Power, System Upgrade and Monitoring

<b>Primary power source</b>	Solar Powered, 5x 2 Watt, 6 Volt solar panels
<b>Battery</b>	Lithium-ion, capacity 11,200 mAh, 3.7 V (rechargeable)
<b>Firmware Upgrade</b>	Standard micro-USB connector (cable included)
<b>System monitoring</b>	Internal temperature, humidity, and solar charging monitored for system health.

## Motion Sensing

<b>Motion Data Format</b>	easting, northing, elevation, latitude, longitude
<b>Wave frequency range</b>	0.03-1 Hz (30s to 1s)
<b>Wave direction range</b>	0 - 360 degrees (full circle)
<b>Sampling rate</b>	2.5 Hz (Nyquist at 1.25 Hz)
<b>Wave displacement accuracy</b>	approximately +/- 2 cm , practical accuracy depends on field of view, conditions, and GPS system status.
<b>Calibration</b>	Not needed, ever.

# Product Specification

## Dimensions and Weight

**Weight** Total weight 5.4 kg (12 lbs), excludes external ballast chain

**Dimensions** Width 42 cm (16.4"), height 31 cm (12.2").

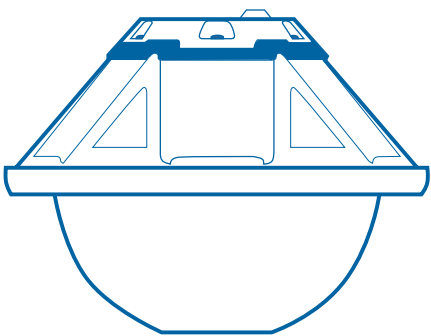
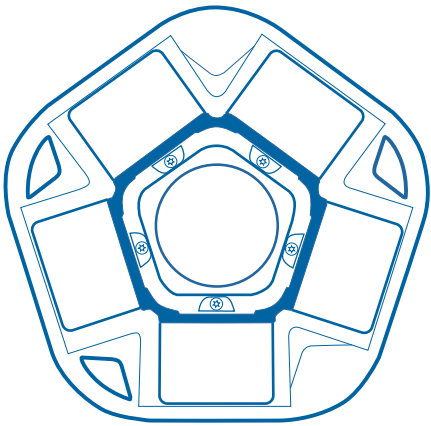

31 cm (12.2")

42 cm (16.4")

## Safety & Compliance

### Trademarks and Patenting

Sofar Spotter and other Sofar products are covered by U.S. and international patents. For a full list of Sofar's patents, please refer to: <https://www.sofaroccean.com/posts/patents>.

The Sofar logo and the terms "Sofar Ocean" and "Spotter" are trademarks belonging to Sofar ocean Technologies, Inc ("Sofar Ocean"). All other related designs, text, graphics, pictures, videos, or any other proprietary intellectual property included with this purchase are the property of Sofar Ocean or its vendors or licensors.

### Terms and Policies

Your purchase and use of Spotter, including any associated software, is subject to the following Sofar policies:

Sofar Terms of Sale

Sofar Terms of Use

Privacy Policy

Warranty Policy

Return Policy

<https://www.sofaroccean.com/legal>

Should you have any questions about these policies or your rights and responsibilities relating thereto, please contact Sofar at [support@sofarocean.com](mailto:support@sofarocean.com)



# Safety & Compliance

## FCC Compliance Statement.

This equipment has been tested and found to comply with the limits for a Class A digital device, pursuant to part 15 of the FCC Rules. These limits are designed to provide reasonable protection against harmful interference when the equipment is operated in a commercial environment. This equipment generates, uses, and can radiate radio frequency energy and, if not installed and used in accordance with the instruction manual, may cause harmful interference to radio communications. Operation of this equipment in a residential area is likely to cause harmful interference in which case the user will be required to correct the interference at his own expense. Changes or modifications next expressly approved by Sofar could void your warranty and your authority to operate this equipment.

This device complies with Part 15 of the FCC Rules. Operation is subject to the following two conditions: (1) this device may not cause harmful interference, and (2) this device must accept any interference received, including interference that may cause undesired operations.

This device contains a certified transmitter module which is located in the electronics package, FCC number Q639603N.

 <b>CAUTION</b>	
	If the device is damaged due to water ingress or otherwise, do not use or charge your Spotter, and disconnect the solar panels.
	Lithium batteries and products that contain them must be disposed of properly. Contact your local waste management company or municipality for safe disposal instructions.

## **Safety and Handling Considerations**

As with any marine activity, take caution when deploying your Spotter. Ensure that you are familiar with the operation of your watercraft and have the necessary safety gear and safety precautions in place prior to your deployment. Secure your Spotter while it is in transit so that it is not lost or damaged. When deploying your Spotter from a boat, stay clear of all lines, especially when deploying a mooring weight.

Your Spotter contains a lithium-ion battery. Do not attempt to replace the battery yourself—you may damage the battery, which could cause overheating, fire, and injury. Do not drop Spotter onto hard surfaces or subject the Spotter to extreme temperatures (below -20C or above 45C) or fire as doing so may damage the Spotter or its battery. Dispose of batteries according to your local environmental laws and guidelines.

Any damage caused to your Spotter by incorrect use or unauthorized modification or disassembly may void your warranty. You are responsible for following all laws and securing all necessary permits required for your application.

## **Disposal Guidelines**

Spotter's electronic components and the lithium-ion battery are not generally suitable for disposal in standard municipal waste systems. Please contact your local provider to determine proper disposal and recycling options. If in doubt, please contact us at [support@sofarocean.com](mailto:support@sofarocean.com) to discuss recycling options for your Spotter.





Sofar Ocean Technologies, Inc.  
Pier 50 Shed B,  
San Francisco, CA 94158  
USA

email [support@sofarocean.com](mailto:support@sofarocean.com)  
phone +1 (415) 230-2299  
visit [www.sofarocean.com](http://www.sofarocean.com)

Copyright 2019, Sofar Ocean Technologies, Inc.  
Version: ENG-201904